

# AZ-07L

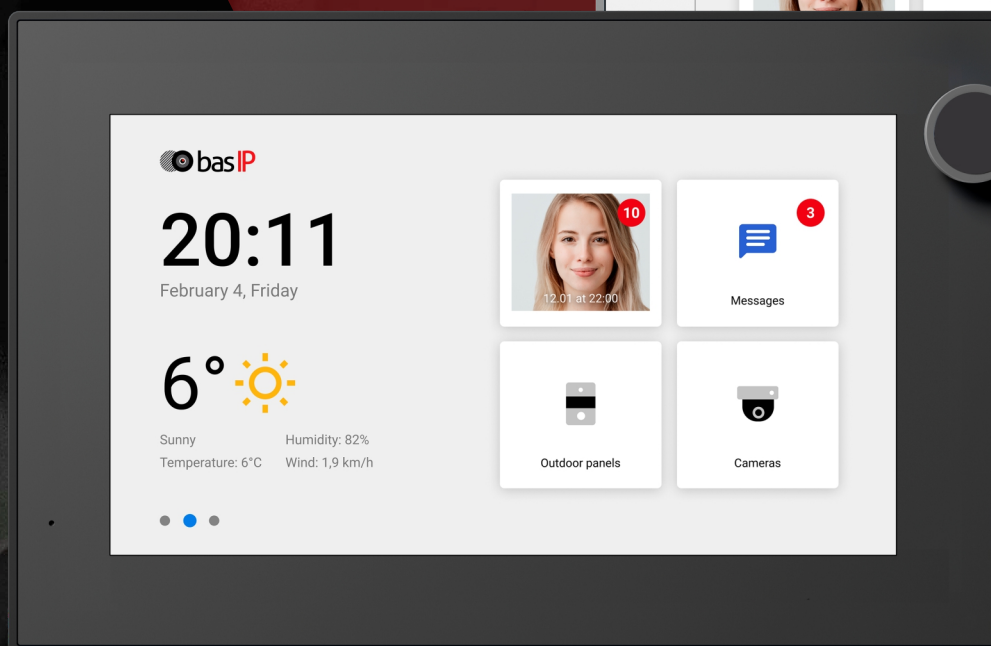

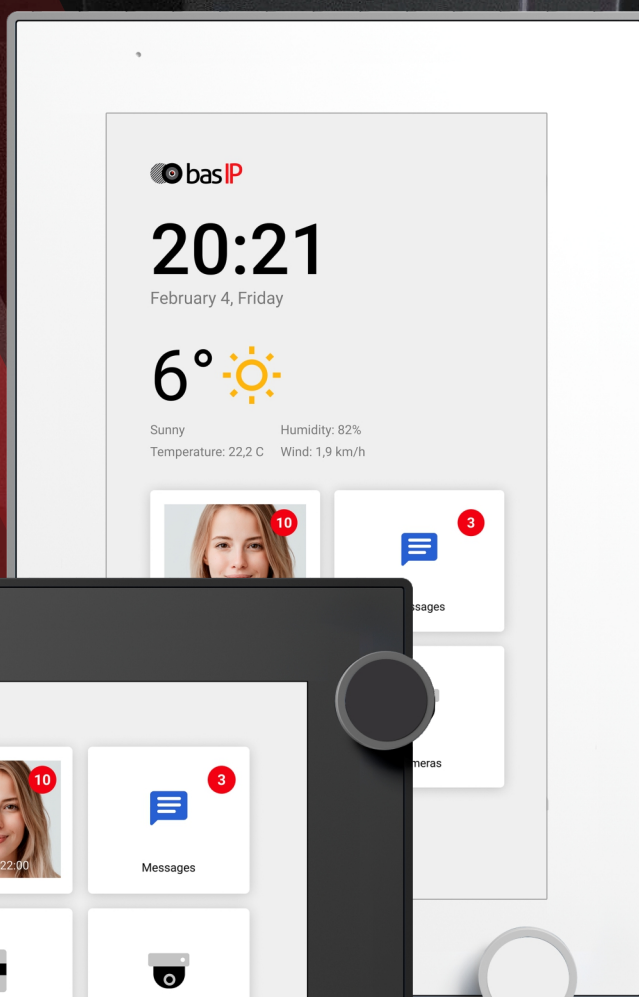
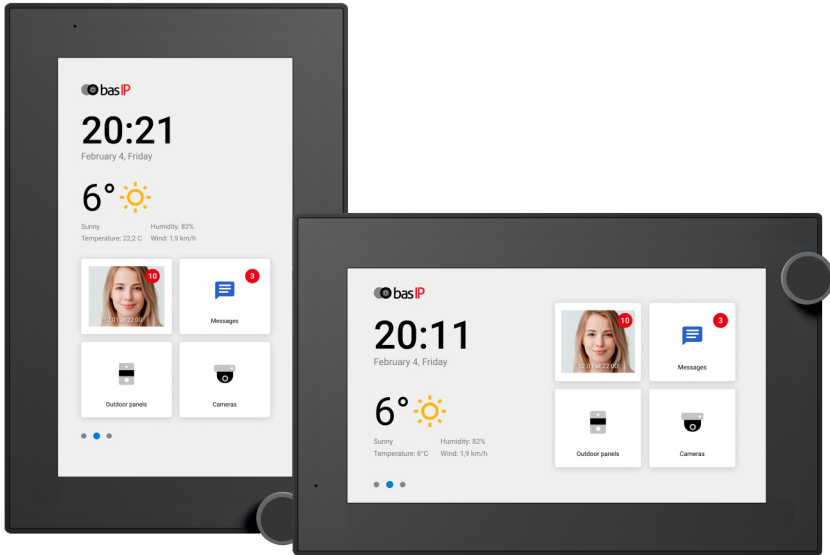

## Main features

- Display: 7" IPS LCD, capacitive touchscreen.
- Screen resolution: 1024 x 600.
- Built-in camera: No.
- Power: PoE and + 12 V DC (PSU not included).
- Power consumption: 6 W, standby 2.5 W.
- Dimensions: 195 x 127 x 27 mm.
- Colors: Black, Gray.
- Body: Plastic.
- Installation Type: Wall mount.
- Mounting options: Horizontal and vertical.

# IP INDOOR VIDEO ENTRY PHONE

---

# AZ-07L

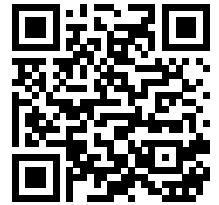

Full User Manual  
[wiki.bas-ip.com](http://wiki.bas-ip.com)

## Device description

7" IP video indoor monitor with overhead horizontal and vertical mounting options, the ability to control the lift, display messages from the management company, PoE, connection of 32 cameras, memory for photos / videos and an autoresponder. OS - Android.

## Appearance

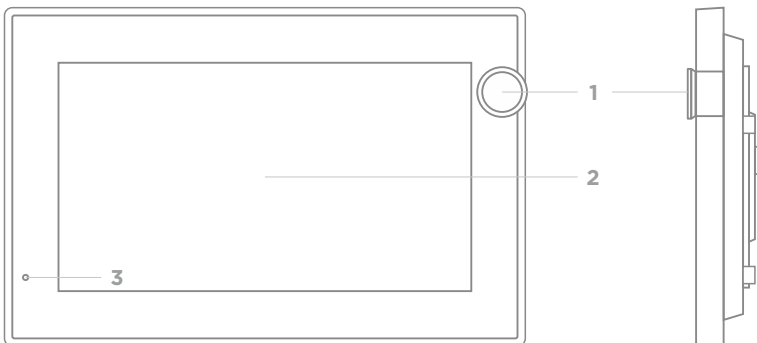

- 1 - Unlock button.
- 2 - Screen
- 3 - Microphone.

## Completeness check of the product

Before installing the monitor, be sure to check that it is complete and all components are available.

### The monitor kit includes:

Monitor	1 pc
Wall mounting bracket	1 pc
Manual	1 pc
Set of wires with connectors for connection of alarm loops, doorbell and home automation	1 pc
Resistors for alarm loops	8 pcs
Installation screws	2 pcs

## Electrical connection

After verifying the device's completeness, you can switch to the monitor connection.

### To connect monitor you will need:

- An Ethernet UTP CAT5 or higher cable connected to a PoE switch or to a normal switch/router.

#### Cable length recommendations

The maximum length of the UTP CAT5 cable segment should not exceed 100 meters, according to the IEEE 802.3 standard.

- Power supply at +12 Volts DC if there isn't PoE.
- Wires must be brought for the connection of alarm loops and home automation (optional).

Power supply  
12V, 2A

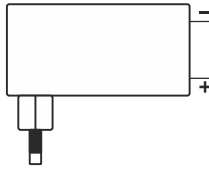

Switch

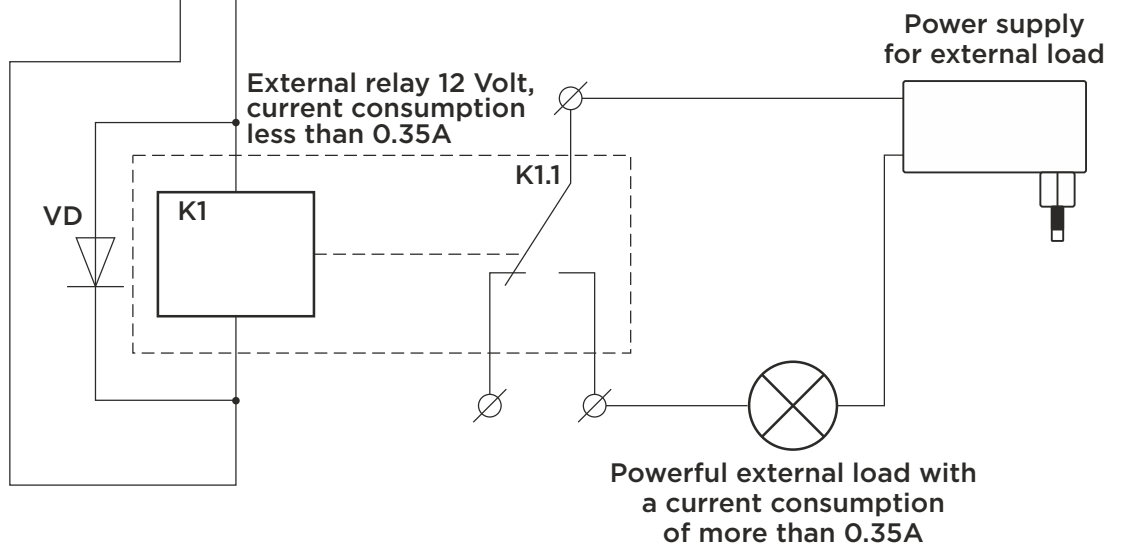
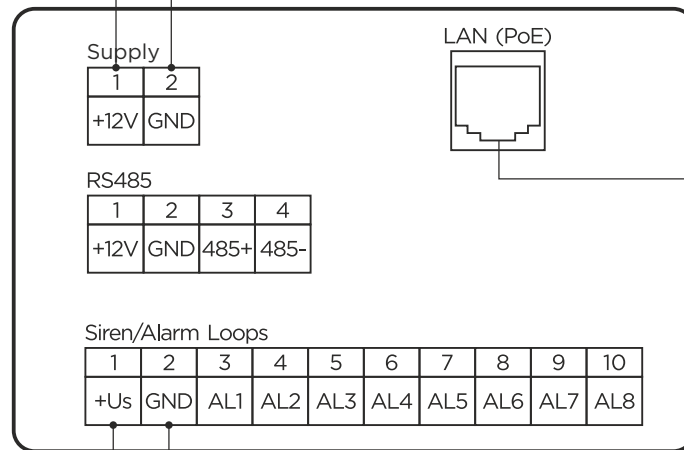
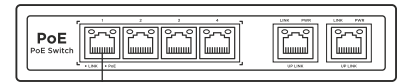

Using the siren output as a controlled output, to control devices or any other external load with high current consumption

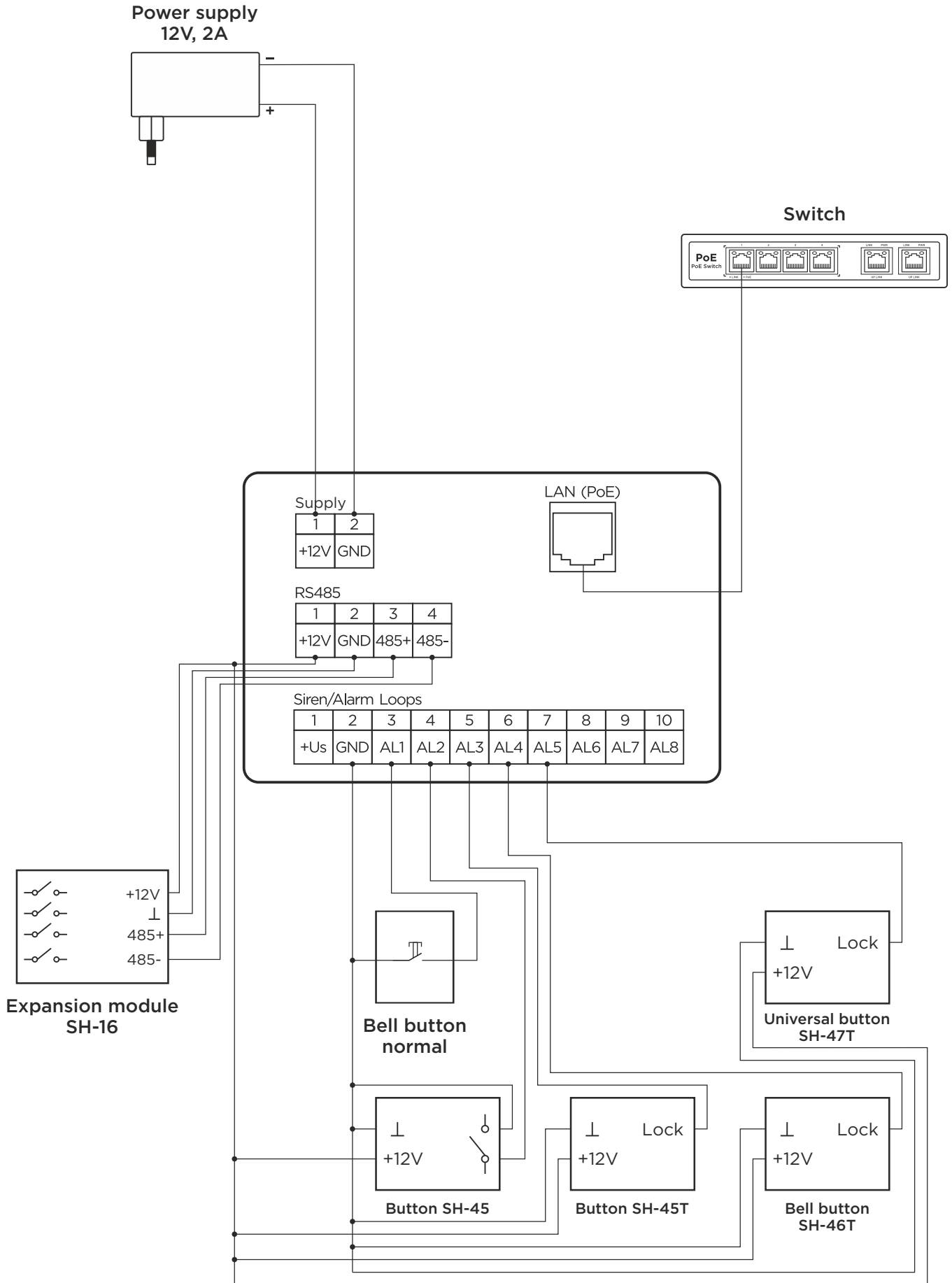

Wiring diagram using various types of buttons connected to alarm loops, and using them as a «Call Button»

Power supply  
12V, 2A

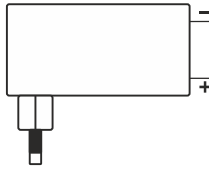

Switch

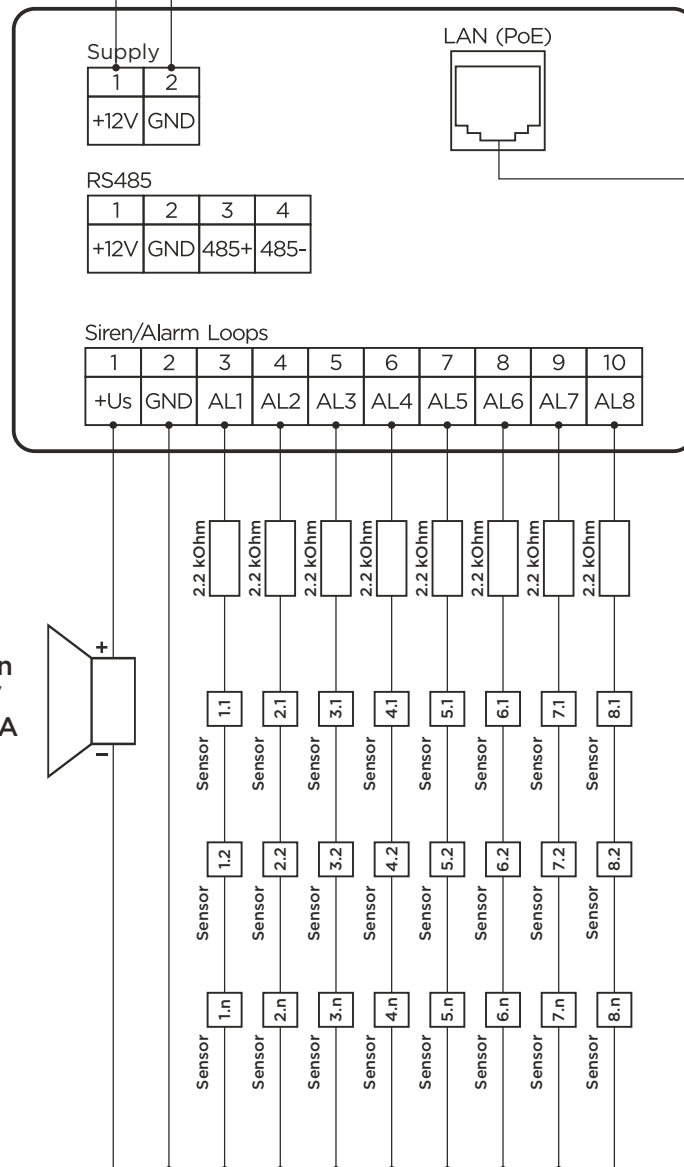
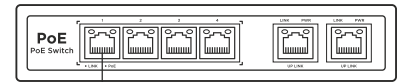

Siren  
12V  
≈ 0,35A

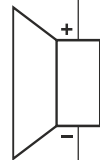

Wiring diagram for security alarm sensors with NC - normally closed contact types

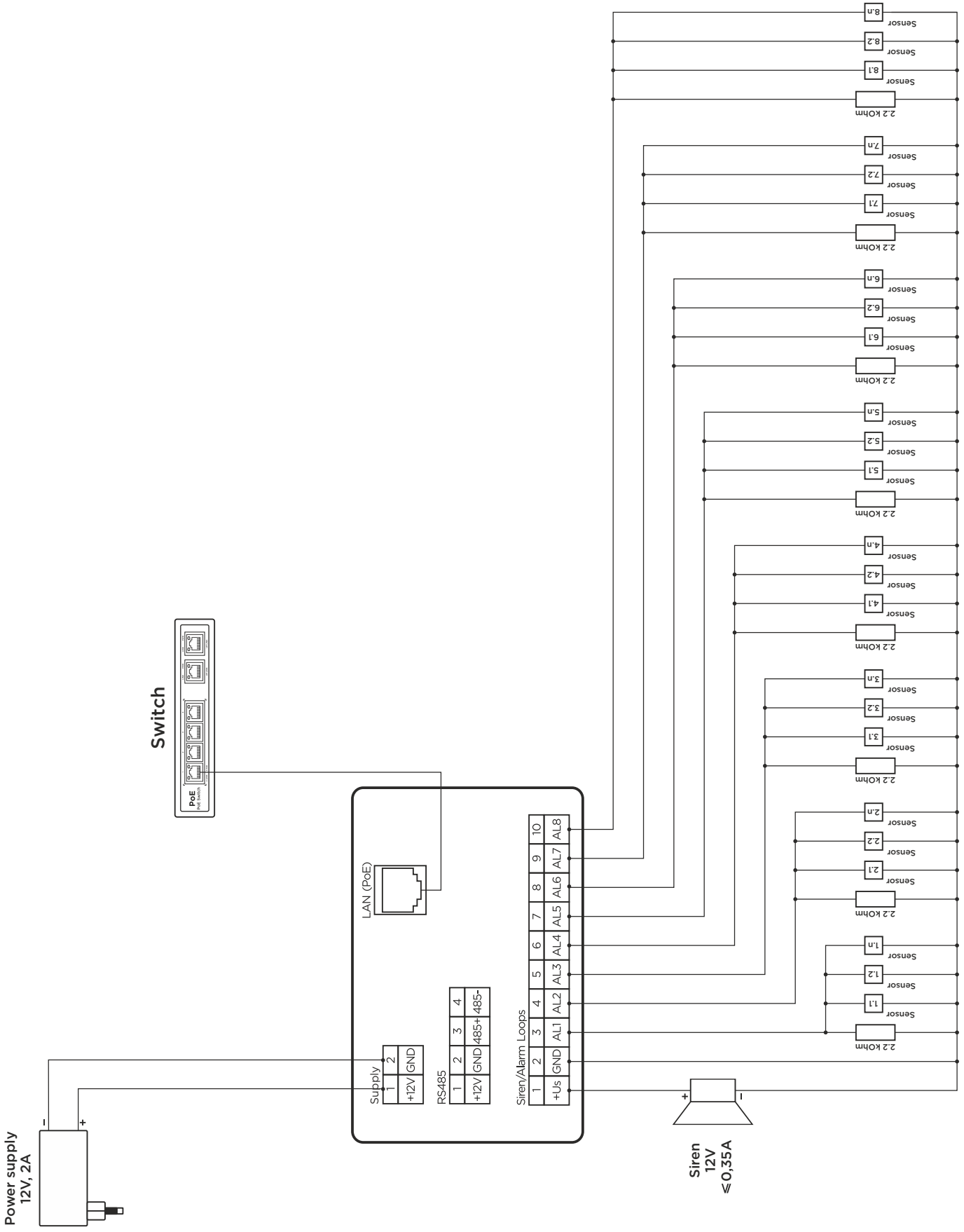

Wiring diagram for security alarm sensors with NO - normally open contact types

## Appearance and mechanical mounting

Before installation of a monitor, it is necessary to drill a hole or a recess into a wall with a 68 mm (2.68in) diameter under the standard mounting box for a 65x45 mm (2.56x2.13in) socket. It is necessary for switching of wires and installation of the monitor.

Attach the bracket in the outlet box using set screws and a phillips head screwdriver.

Installation of the monitor on the bracket is done from top to bottom.

### Vertical mounting

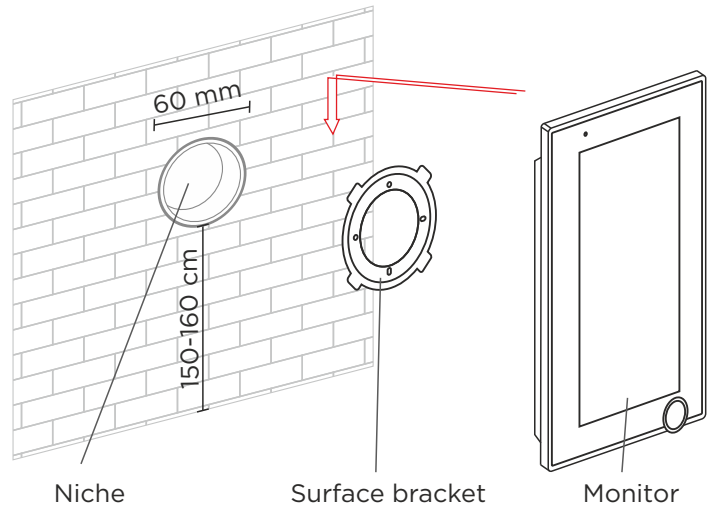
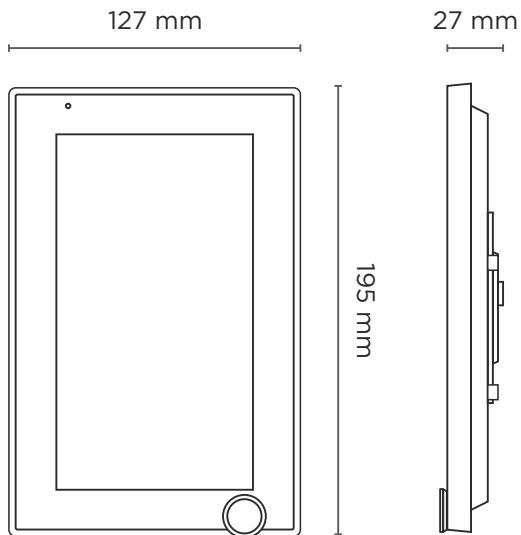

### Horizontal mounting

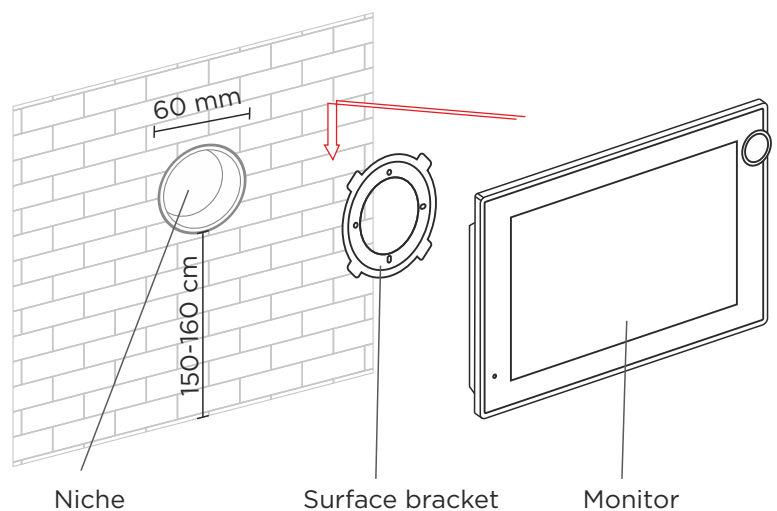
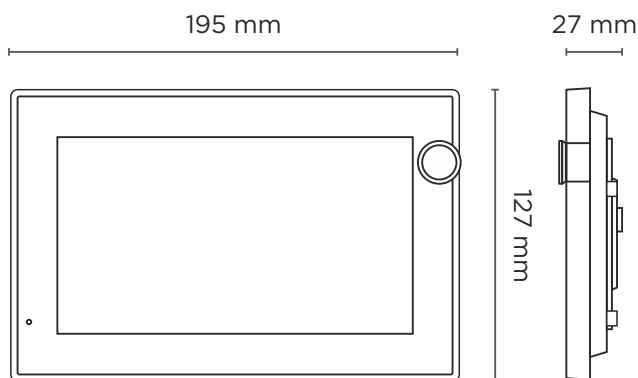



## Warranty

The warranty card number \_\_\_\_\_

Model name \_\_\_\_\_

Serial number \_\_\_\_\_

Seller name \_\_\_\_\_

With following stated terms of warranty is familiar, functional test was performed in my presence:

Customer signature \_\_\_\_\_

## Warranty conditions

**The warranty period of the product — 36 (thirty-six) months from the date of sale.**

- Transportation of product must be in its original packaging or supplied one by the seller.
- The product is accepted in warranty repair only with a properly filled warranty card and the presence of intact stickers or labels.
- The product is accepted for examination in accordance with the cases provided by law, only in the original packaging, in a full complete set, appearance corresponding to the new equipment and presence of all relevant properly filled documents.
- This warranty is in addition to the constitutional and other consumer rights and in no way restrict them.

## Terms of warranty

- The warranty card must indicate the name of the model, serial number, purchase date, name of the seller, seller company stamp and the customer's signature.
- Delivery to the warranty repair is carried out by the buyer himself.
- Warranty repairs carried out only during the warranty period specified in the warranty card.
- The service center is committed to do everything possible to carry out the repair warranty products, up to 24 working days. The period spent on the restoration of product functionality is added to the warranty period.







[www.bas-ip.com](http://www.bas-ip.com)